

# **Kelly KBS Brushless Motor Controller User's Manual**

## **Devices Supported:**

<b>KBS24051</b>	<b>KBS24101</b>
<b>KBS24121</b>	<b>KBS36051</b>
<b>KBS36101</b>	<b>KBS48051</b>
<b>KBS48051E</b>	<b>KBS48101</b>
<b>KBS48121</b>	<b>KBS72051</b>
<b>KBS72101</b>	<b>KBS72121</b>

# Contents

Kelly KBS Brushless Motor.....	0
Controller User’s Manual.....	0
Contents.....	1
Chapter 1 Introduction.....	2
1.1 Overview.....	2
Chapter 2 Features and Specifications.....	3
2.1 General functions.....	3
2.2 Features.....	4
2.3 Specifications.....	4
2.4 Name Regulation.....	5
Chapter 3 Wiring and Installation.....	6
3.1 Mounting the Controller.....	6
3.2 Connections.....	7
3.3 Installation Check List.....	10
Chapter 4 Maintenance.....	12
4.1 Cleaning.....	12
4.2 Configuration.....	12
Table 1: LED CODES.....	13
Green LED Codes.....	13
Red LED Codes.....	13
Contact Us:.....	15

# Chapter 1 Introduction

## 1.1 Overview

The manual introduces Kelly Small BLDC motor controller features, installation and maintenance. Read the manual carefully and thoroughly before use the controller. Should you have any questions, please contact the support center of Kelly Controls, LLC.

Kelly's programmable motor controllers provide efficient, smooth and quite controls for electric motorcycle, golf cart, go-cart, as well as industry motor speed or torque control. It uses high power MOSFET, PWM to achieve efficiency 99% in most cases. Powerful microprocessor brings in comprehensive and precise control to the controllers. It also allows users to set parameters, conduct tests, and obtain diagnostic information quickly and easily.

## Chapter 2 Features and Specifications

### 2.1 General functions

- (1) Extended fault detection and protection. LED flashing for fault code indicates fault sources.
- (2) Monitoring battery voltage. It will stop driving if battery voltage is too high. It will cut back then stop driving if voltage is going too low.
- (3) Built-in current loop and over current protection.
- (4) Motor temperature input and protection. Configurable range.
- (5) Current cutback at low temperature and high temperature to protect battery and controller. The current will ramp down quickly if controller temperature is higher than 90C, and shutdown at 100C. Low temperature current ramping down usually starts at 0C.
- (6) The controller keeps monitoring voltage during regen. It will cut back current then cut off regen if voltage is going too high.
- (7) Configurable to limit max reverse speed to half of max forward speed
- (8) Configurable and programmable with RS-232. Software upgradeable. Windows GUI provided.
- (9) Provide power supply (5V) for hall sensors and other sensors.
- (10) 3 switch inputs. Close to ground to activate. Default to throttle switch, brake switch and reverse switch.
- (11) 3 analog inputs, 0-5V. Default to throttle input, brake input and motor temperature input
- (12) PWMable reverse alarm output. Recirculation diodes provided.
- (13) Main contactor driver. Cutting off the power if any fault is detected.
- (14) Current meter to display both drive and regen current. Save shunt!
- (15) Configurable boost switch. Output the maximum current achievable if the switch is enabled and turned on.
- (16) Configurable turbo switch. Limiting max power to half if the switch is enabled and turned on.
- (17) Configurable max reverse power to half.
- (18) Enhanced regen brake function. Novel ABS technique provides powerful and smooth regen.
- (19) Configurable 12V brake signal input, in lieu of motor temperature sensor.
- (20) Optional joystick throttle. Single 0-5V signal for both forward and reversing.
- (21) Motor over temperature detection and protection, with recommended thermistor.
- (22) 3 hall position sensor inputs. Open collector, pull up provided.
- (23) Optional supply voltage 8V-30V.

*Caution! Regeneration has braking effect, but can't replace mechanical brake. Mechanical brake is required to stop your vehicle. Regen isn't a safety feature! Controller may stop regen to protect itself (not you!).*

## 2.2 Features

- 1) Intelligence with powerful microprocessor.
- 2) Synchronous rectification, ultra low drop, fast PWM to achieve very high efficiency.
- 3) Electronic reversing.
- 4) Voltage monitoring on 3 motor phases, bus, and power supply.
- 5) Voltage monitoring on voltage source 12V and 5V.
- 6) Current sense on all 3 motor phases.
- 7) Current control loop.
- 8) Hardware over current protection.
- 9) Hardware over voltage protection.
- 10) Configurable limit for motor current and battery current.
- 11) Support torque mode, speed mode, and balanced mode operation.
- 12) Low EMC.
- 13) LED fault code.
- 14) Battery protection: current cutback, warning and shutdown at configurable high and low battery voltage.
- 15) Rugged aluminum housing for maximum heat dissipation and harsh environment.
- 16) Rugged high current terminals, and rugged aviation connectors for small signal.
- 17) Thermal protection: current cut back, warning and shutdown on high temperature.
- 18) Configurable 60 degree or 120 degree hall position sensors.
- 19) Support motors with any number of poles.
- 20) Up to 40,000 electric RPM standard. Optional high speed 70,000 ERPM  
(Electric RPM = mechanical RPM \* motor pole pairs).
- 21) Support three modes of regenerative braking: brake switch regen, release throttle regen, 0-5V analog signal variable regen.
- 22) Configurable high pedal protection: Disable operation if power up with high throttle.
- 23) Current multiplication: Take less current from battery, output more current to motor.
- 24) Easy installation: 3-wire potentiometer will work.
- 25) Standard PC/Laptop computer to do programming. No special tools needed.
- 26) User program provided. Easy to use. No cost to customers.

## 2.3 Specifications

- Frequency of Operation: 16.6kHz.
- Standby Battery Current: < 0.5mA.
- 5V Sensor Supply Current: 40mA.
- Controller supply voltage range: PWR, 18V to 90V for controllers rated equal or lower than 72V. 8V to 30V for 24V controller.
- Supply Current, PWR, 150mA.
- Configurable battery voltage range, B+. Max operating range: 18V to 1.25\*Nominal Voltage.
- Standard Throttle Input: 0-5 Volts(3-wire resistive pot), 1-4 Volts(hall active throttle).
- Analog Brake and Throttle Input: 0-5 Volts. Can use 3-wire pot to produce 0-5V signal.

- Reverse Alarm, Main Contactor Coil Driver, Meter: <200mA.
- Full Power Operating Temperature Range: 0°C to 50°C (controller case temperature).
- Operating Temperature Range: -30°C to 90°C, 100°C shutdown (controller case temperature).
- Motor Current Limit, 10 seconds boost: 50A-120A ,depending on the model.
- Motor Current Limit, continuous: 20A-50A ,depending on the model.
- Max Battery Current :Configurable.

## 2.4 Name Regulation

The name regulation of Kelly BLDC motor controllers:

# KBS48101

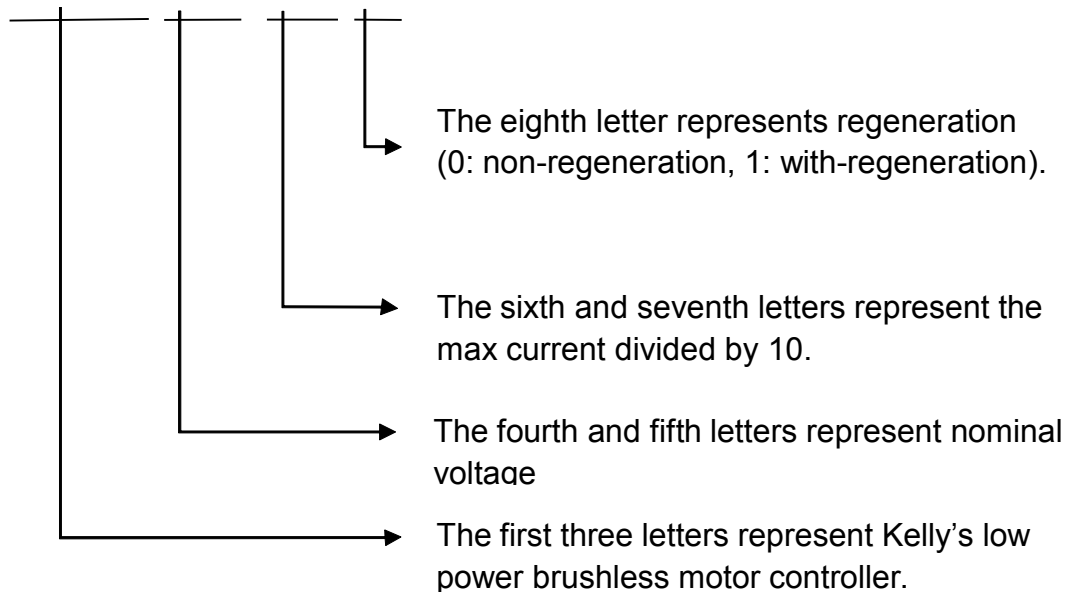

# Chapter 3 Wiring and Installation

## 3.1 Mounting the Controller

The controller can be oriented in any position as clean and dry as possible, or shield with a cover to protect it from water and contaminants.

To ensure full rated output power, the controller should be fastened to a clean, flat metal surface with four screws. Applying silicon gel or other thermal conductive material to contact surface will enhance thermal performance.

Sufficient heat sink and airflow are required for high power application.

The case outline and mounting hole dimensions are shown in Figure 1.

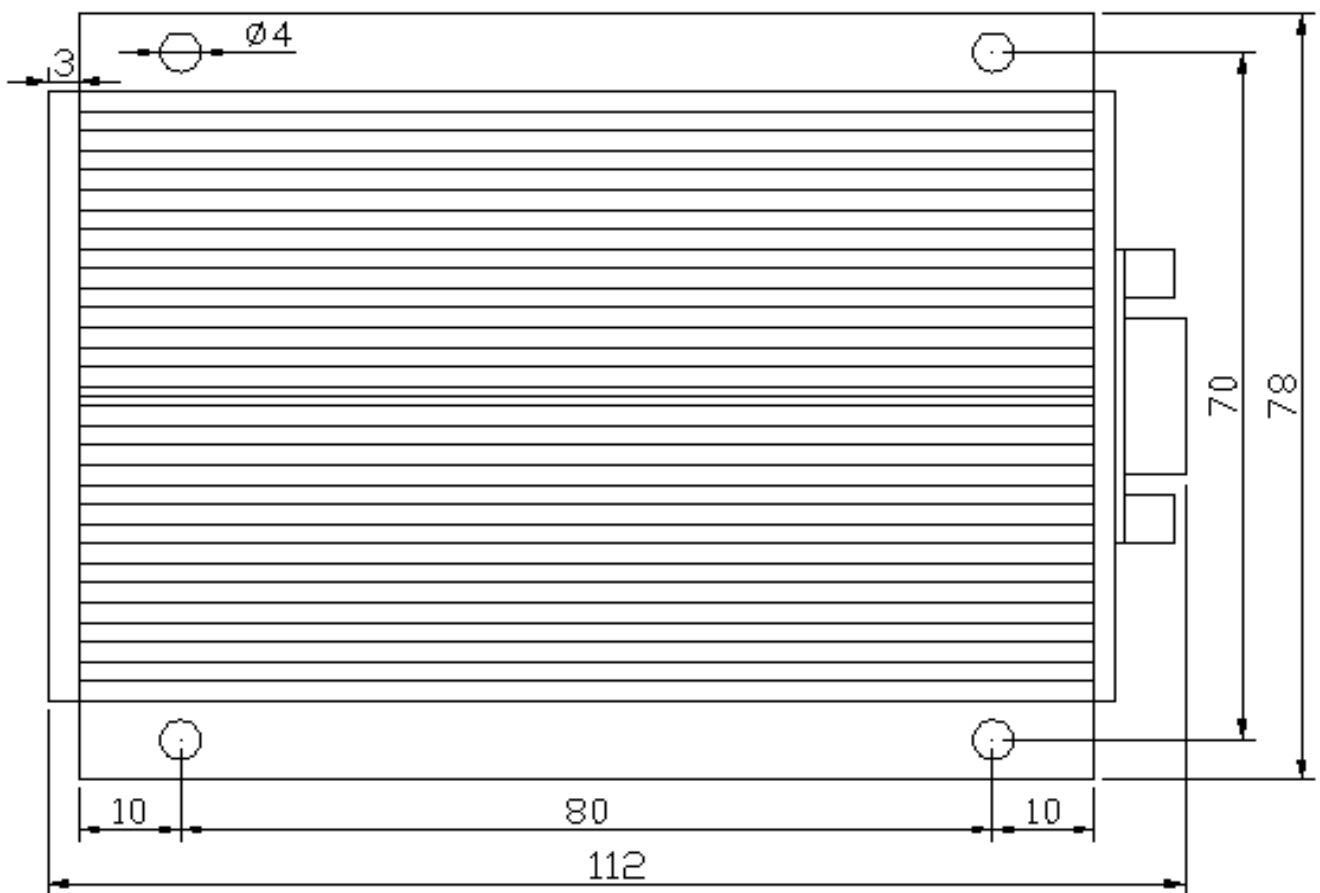

Height: 41 millimeters

**Figure 1:** mounting hole dimensions (dimensions in millimeters)

### 3.2 Connections

#### 3.2.1 Pin definition of KBS Controller

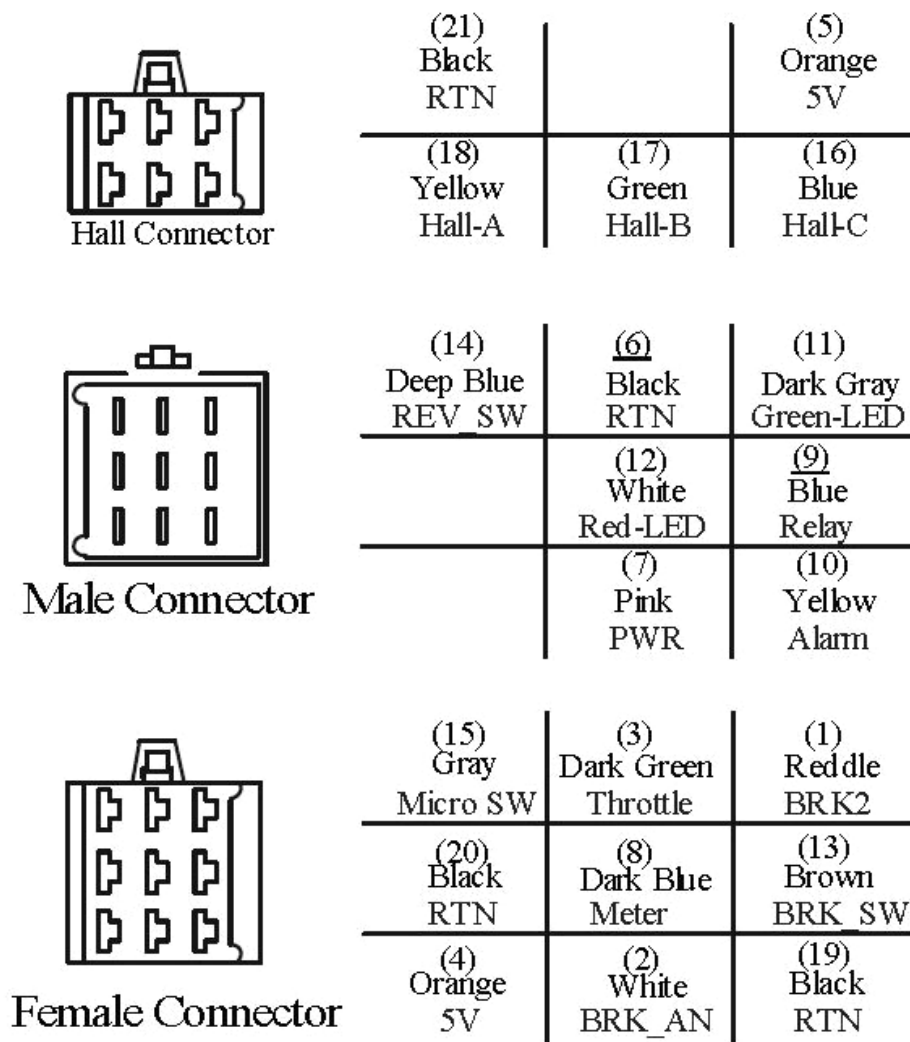

**Figure 2:** connector pin definition diagram

#### Hall Connector Pin Definition

- (21) RTN:**Signal return. **Black**
- (5) 5V:** 5V supply output, <40mA. **Orange**
- (18) Hall A:** Hall phase A. **Yellow**
- (17) Hall B:** Hall phase B. **Green**
- (16) Hall C:** Hall phase C. **Blue**

#### Male Connector Pin Definition

- (14) REV\_SW:** Reverse switch input. **Deep Blue**
- (6) RTN:** Signal return or power supply return. **Black**
- (11) Green-LED:** Running indication. **Dark Gray**

- (12) Red-LED: Fault code. White
- (9) Relay: Main contactor driver, <200mA. Blue
- (7) PWR: Controller power supply (input). Pink
- (10) Alarm: To drive reverse beeper, <200mA. Yellow

## Female Connector Pin Definition

- (15) Micro\_SW: Throttle switch input. Gray
- (3) Throttle: Throttle analog input, 0-5V. Dark Green
- (1) BRK2: 12V Brake switch input or Motor temperature sensor input. Reddle.
- (20) RTN: Signal return. Black
- (8) Meter: Current meter, <200mA. Dark Blue
- (13) BRK\_SW: Brake switch input. Brown
- (4) 5V: 5V supply output, <40mA. Orange
- (2) BRK\_AN: Brake analog input, 0-5V. White
- (19) RTN: Signal return. Black

### Notes:

1. All RTN pins are internally connected.
2. Recirculation diodes are provided in the controller to PWR for alarm and Contactor coil driver.
3. Kelly Ampmeter positive connect to 5V power supply of controller, negative to Dark Blue wire.
4. Switch to ground is active. Open switch is inactive.

**Caution: Make sure all connections are correct before apply power. Otherwise it may damage the controller! Please securely wire B- before applying power. It's preferred to place contactor or breaker on B+. Please place precharge resistor on any breaker! It can cause damage without it!!!**

### 3.2.2 Wiring of KBS Controller

#### 3.2.2.1 Standard wiring of KBS controller

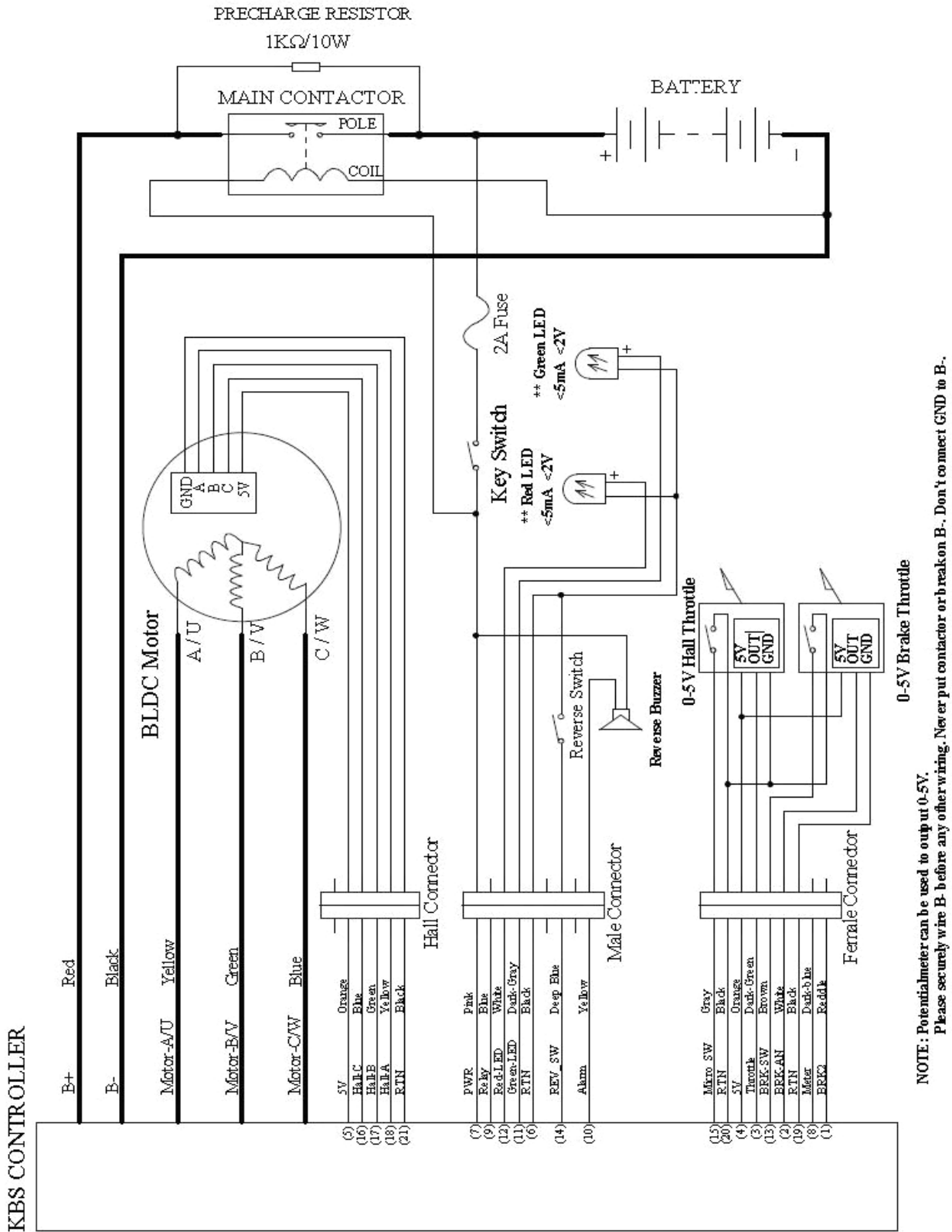

**Figure 3:** KBS controller standard wiring  
(Battery voltage can be used for controller supply)

3.2.2.2 Optional wiring of KBS controller

The output signal of the pin is for 5V current meter.

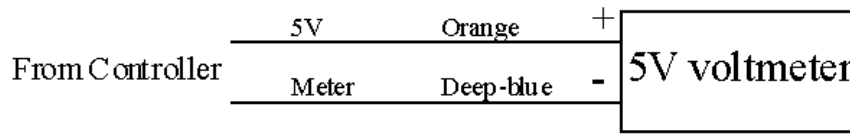

**Figure 4:** wiring of curretn meter pin

The 12V input signal of the pin supplies the second braking function of the controller.

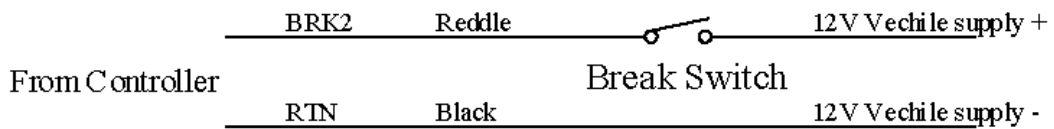

**Figure 5:** wiring of BRK2

**3.2.3 Communication Port**

A RS232 port is provided to communicate with host computer for calibration and configuration.

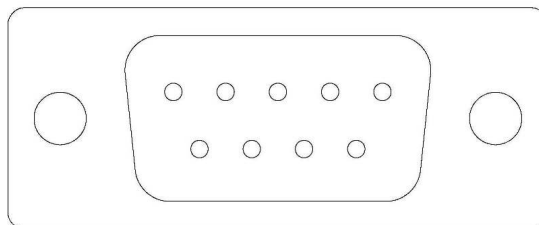

**Figure 6:** RS232 Interface

**3.3 Installation Check List**

Before operating the vehicle, complete the following checkout procedure. Use LED code as a reference. LED codes are listed in Table 1.

**Caution:**

- Put the vehicle up on blocks to get the drive wheels off the ground before beginning these tests.
- Do not allow anyone to stand directly in front of or behind the vehicle during the checkout.
- Make sure the PWR switch and the brake is off
- Use well-insulated tools.

- Make sure the wire is connected correctly
- Turn the PWR switch on. The LED should blink, then keeps on when the controller operates normally. If this does not happen, check continuity of the PWR and return.
- The fault code will be detected automatically at restart.
- With the brake switch open, select a direction and operate the throttle. The motor should spin in the selected direction. Please verify wiring and voltage if it doesn't. Also check fuse. The motor should run faster with increasing throttle. If not, refer to Table 1 LED code, and correct the fault according to the code.
- Take the vehicle off the blocks and drive it in a clear area. It should have smooth acceleration and good power.

## Chapter 4 Maintenance

There are no user-serviceable parts inside the controllers. Do not attempt to open the controller. Or will void warranty. However, cleaning the controller exterior periodically should be necessary.

The controller is inherently a high power device. When working with any battery powered vehicle, proper safety precautions should be taken. These include, but are not limited to, proper training, wearing eye protection, avoiding loose clothing and jewelry, and using insulated tools.

### 4.1 Cleaning

Although the controller requires virtually no maintenance after properly installation, the following minor maintenance is recommended in certain applications.

- Remove power by disconnecting the battery, starting with battery positive.
- Discharge the capacitors in the controller by connecting a load (such as a contactor coil, resistor or a horn) across the controller's B+ and B- terminals.
- Remove any dirt or corrosion from the bus bar area. The controller should be wiped with a moist rag. Be sure it is dry before reconnecting the battery.
- Make sure the connections to the bus bars are tight. Use two wrenches for this task in order to avoid stressing the bus bars; the wrenches should be well insulated.

### 4.2 Configuration

You can configure the controller with a host computer through RS232 or USB port.

- Use straight through RS232 cable or USB converter provide by Kelly to connect the D9 connector to a host computer. Provide >18V to PWR (24V controller only provide >8V) . Wire power supply return to any RTN pin.
- Do not connect B+, throttle and so on. The controller may display fault code, but it doesn't affect programming or configuration.

Download and setup the configuration software:

<http://www.kellycontroller.com/support.php>

## Table 1: LED CODES

### Green LED Codes

LED Code	Explanation	Solution
Green Off	No power or not operating	1. Check if all wires are correct. 2. Check fuse and power supply.
Green On	Normal operation	That's great! You got solution!
Green and Red LED Keep On		1. Software is upgrading. 2. Supply voltage too low or battery too high 3. The controller is damaged. Please contact Kelly for warrantee.

### Red LED Codes

LED Code	Explanation	Solution
1,2    α    αα	Over voltage error	1. Battery voltage is higher than max operating voltage of the controller. Please check the battery voltage and configuration. 2. Over voltage at regeneration. Controller will cut back or stop regeneration. 3. Please note there could be 2% error with Overvoltage setting.
1,3    α    ααα	Low voltage error	1. The controller will attempt to clear the fault code automatically after 5 second if battery voltage returns to normal. 2. Check the battery voltage. 3. Charge battery if necessary.
1,4    α    αααα	Over temperature warning	1. The controller temperature is over 90°C. The controller will cut back current in the case. Stop or reduce output to ensure the temperature fall. 2. Improve heat sink or airflow.
2,1    αα    α	Motor fails to start	1. Motor hasn't reached 25 electrical RPM after 2 seconds from starting. Most likely the hall or phase wiring problem.
2,2    αα    αα	Internal voltage fault	1. Check if the B+ and PWR voltage are correct, refer to B- or RTN. Could be PWR voltage low. 2. Please check load on 5V supply. Could be high load on 5V. Incorrect pot wiring can load it heavily. 3. The controller is damaged. Please contact Kelly for warrantee.
2,3    αα    ααα	Over temperature	1. The controller temperature is over 100°C. Controller stops driving in the case. 2. Stop driving and wait for temperature fall. The co

			ntroller will restart if temperature drops below 80°C.
2,4	▣▣ ▣▣▣▣	Throttle error at power up	<ol style="list-style-type: none"> <li>1. The throttle signal is higher than configured dead zone at power-on</li> <li>2. The fault will disappear if restart or release throttle.</li> </ol>
3,1	▣▣▣ ▣	Frequent reset	<ol style="list-style-type: none"> <li>1. It can be caused by over current, bad motor, bad ground wiring or so.</li> </ol>
3,2	▣▣▣ ▣▣	Internal reset	Reset caused by over current, high battery voltage or low supply voltage. It is normal if occurs occasionally.
3,3	▣▣▣ ▣▣▣	Throttle short or open circuit when using 1-4v hall sensor throttle	<ol style="list-style-type: none"> <li>1. Check whether the throttle is short or open up.</li> <li>2. When the throttle is normal, restart will clear the error.</li> </ol>
3,4	▣▣▣ ▣▣▣▣	Throttle isn't zero when try to change direction	The controller won't change drive direction if throttle isn't zero. Also it won't change direction at high speed. The controller will wait throttle and speed close to zero before change direction.
4,1	▣▣▣▣ ▣	Over voltage at startup or regeneration	The controller won't drive motor if detect overvoltage at power up. It will cut back regen current or stop regen at overvoltage. You may set max voltage threshold with GUI.
4, 2	▣▣▣▣ ▣▣	Hall sensor signal error	<ol style="list-style-type: none"> <li>1. Most likely caused by incorrect hall wiring, to wrong pin or loose wire.</li> <li>2. Intermittent or damaged hall sensor</li> <li>3. Double check hall angle setting, 60 degree or 120 degree</li> </ol>
4, 3	▣▣▣▣ ▣▣▣	Motor over temperature	<ol style="list-style-type: none"> <li>1.The motor temperature higher than configured max temperature. Controller will shutdown and wait for motor temperature drops.</li> <li>2.Can change the temperature setting with configuration program.</li> </ol>

The Red LED flashes once at power on, then keeps off for normal operation. "1, 2" means it flashed once, then flashes twice after 1 second. The time between two flashes is 0.5 second. The pause time between one error code and another error code is 2 second.

## Contact Us:

**Kelly Controls, LLC**

**Home Page:**

<http://www.KellyController.com>

**E-mail:**

[Support@KellyController.com](mailto:Support@KellyController.com)

**Phone:**

(01) 224 637 5092